

# 700 mA Dual H-Bridge Motor Driver with 3.0 V Compatible Logic I/O

The 17531A is a monolithic dual H-Bridge power IC ideal for portable electronic applications containing bipolar step motors and/or brush DC-motors (e.g., cameras and disk drive head positioners).

The 17531A operates from 2.0 V to 8.6 V using the internal charge pump, with independent control of each H-Bridge via parallel MCU interface. The device features built-in shoot-through current protection and an undervoltage shutdown function.

The 17531A has four operating modes: Forward, Reverse, Brake, and Tri-Stated (High Impedance). The 17531A has a low total  $R_{DS(ON)}$  of 1.2  $\Omega$  (max @ 25°C).

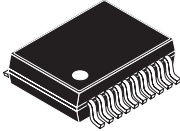
The 17531A efficiently drives many types of micromotors with low power dissipation owing to its low output resistance and high output slew rates. The H-Bridge outputs can be independently pulse width modulated (PWM'ed) at up to 200 kHz for speed/torque and current control.

## Features

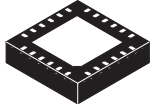
- Low Total RDS(ON) 0.8 W (Typ), 1.2  $\Omega$  (Max) @ 25°C
- Output Current 0.7 A (DC)
- Shoot-Through Current Protection Circuit
- PWM Control Input Frequency up to 200 kHz
- Built-In Charge Pump Circuit
- Low Power Consumption
- Undervoltage Detection and Shutdown Circuit
- Power Save Mode with Current Draw  $\leq 2.0 \mu\text{A}$
- Pb-Free Packaging Designated by Suffix Codes EV and EP

**17531A**

**DUAL H-BRIDGE**

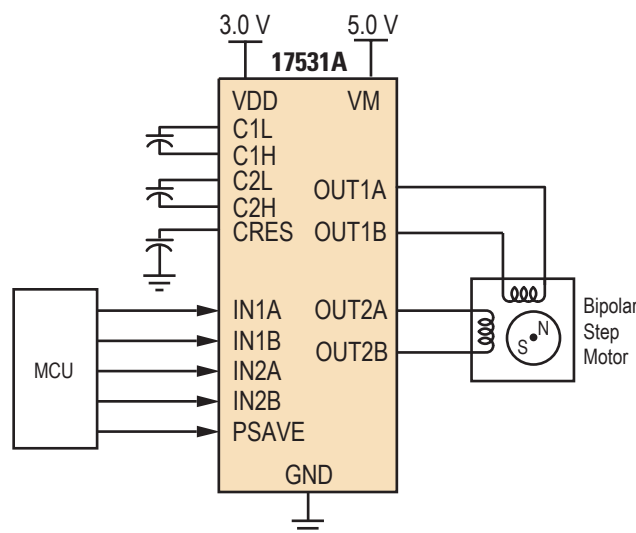


**VMFP SUFFIX**  
**EV SUFFIX (PB-FREE)**  
**98ASA10616D**  
**20-TERMINAL VMFP**



**QFN SUFFIX**  
**EP SUFFIX (PB-FREE)**  
**98ARL10577D**  
**24-TERMINAL QFN**

ORDERING INFORMATION		
Device	Temperature Range (T <sub>A</sub> )	Package
MPC17531AEV/EL	-20°C to 65°C	20 VMFP
MPC17531AEP/R2		24 QFN



**Figure 1. 17531A Simplified Application Diagram**

Freescale Semiconductor, Inc. reserves the right to change the detail specifications, as may be required, to permit improvements in the design of its products.

© Freescale Semiconductor, Inc., 2005. All rights reserved.

### INTERNAL BLOCK DIAGRAM

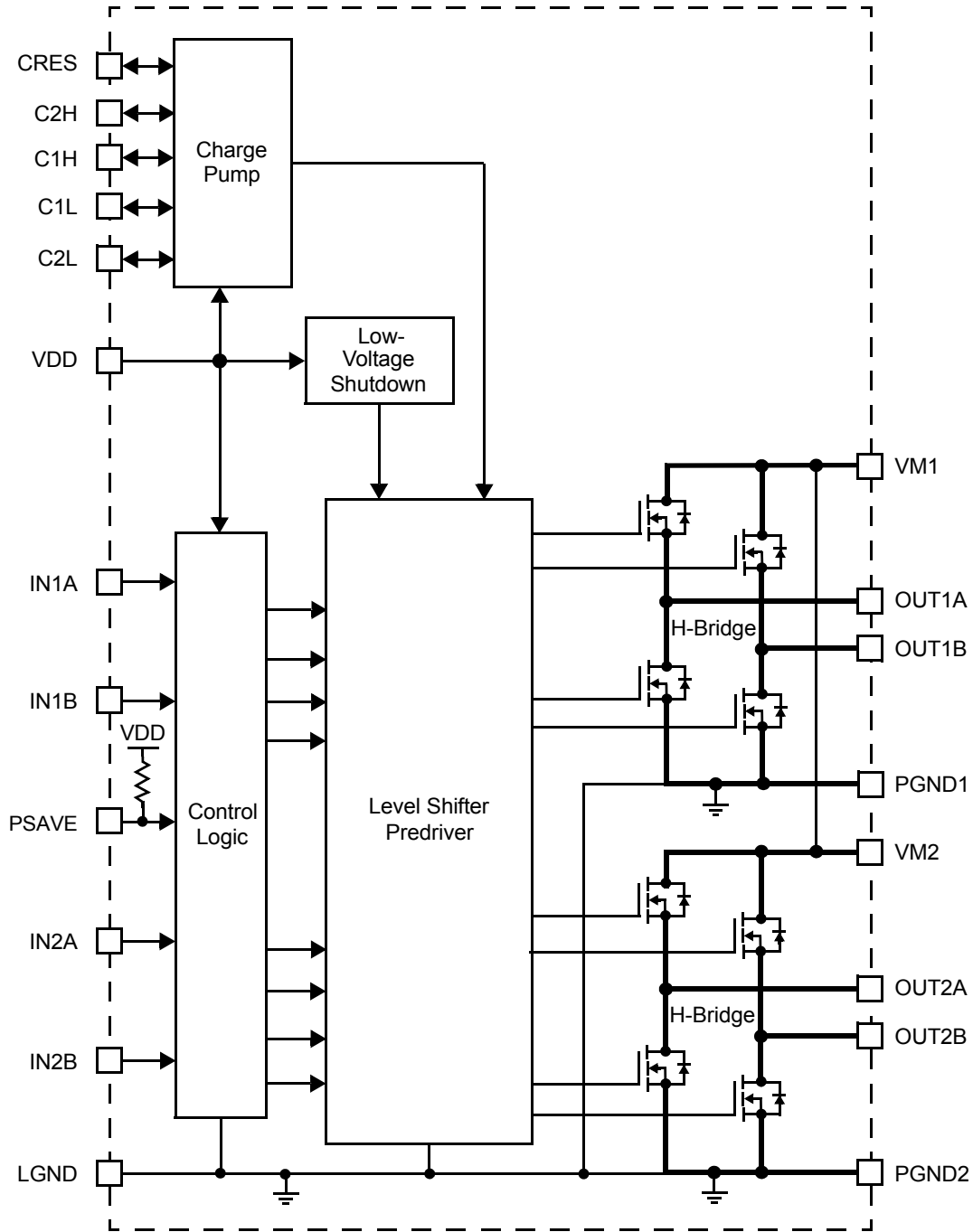


Figure 2. 17531A Simplified Internal Block Diagram

## TERMINAL CONNECTIONS

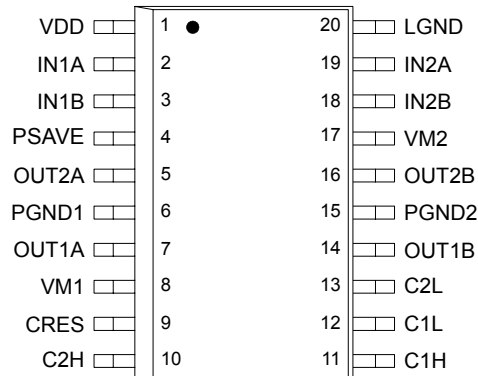


Figure 3. 17531A, 20-Terminal VMFP Connections

Table 1. 17531A, 20-Terminal VMFP Definitions

A functional description of each terminal can be found in the Functional Terminal Description section beginning on [page 10](#).

Terminal Number	Terminal Name	Formal Name	Definition
1	VDD	Logic Supply	Control circuit power supply terminal.
2	IN1A	Logic Input Control 1A	Logic input control of OUT1A (refer to <a href="#">Table 6, Truth Table, page 9</a> ).
3	IN1B	Logic Input Control 1B	Logic input control of OUT1B (refer to <a href="#">Table 6, Truth Table, page 9</a> ).
4	PSAVE	Power Save	Logic input controlling power save mode.
5	OUT2A	H-Bridge Output 2A	Output A of H-Bridge channel 2.
6	PGND1	Power Ground 1	High-current power ground 1.
7	OUT1A	H-Bridge Output 1A	Output A of H-Bridge channel 1.
8	VM1	Motor Drive Power Supply 1	Positive power source connection for H-Bridge 1 (Motor Drive Power Supply).
9	CRES	Predriver Power Supply	Internal triple charge pump output as predriver power supply.
10	C2H	Charge Pump 2H	Charge pump bucket capacitor 2 (positive pole).
11	C1H	Charge Pump 1H	Charge pump bucket capacitor 1 (positive pole).
12	C1L	Charge Pump 1L	Charge pump bucket capacitor 1 (negative pole).
13	C2L	Charge Pump 2L	Charge pump bucket capacitor 2 (negative pole).
14	OUT1B	H-Bridge Output 1B	Output B of H-Bridge channel 1.
15	PGND2	Power Ground 2	High-current power ground 2.
16	OUT2B	H-Bridge Output 2B	Output B of H-Bridge channel 2.
17	VM2	Motor Drive Power Supply 2	Positive power source connection for H-Bridge 2 (Motor Drive Power Supply).
18	IN2B	Logic Input Control 2B	Logic input control of OUT2B (refer to <a href="#">Table 6, Truth Table, page 9</a> ).
19	IN2A	Logic Input Control 2A	Logic input control of OUT2A (refer to <a href="#">Table 6, Truth Table, page 9</a> ).
20	LGND	Logic Ground	Low-current logic signal ground.

Transparent Top View of Package

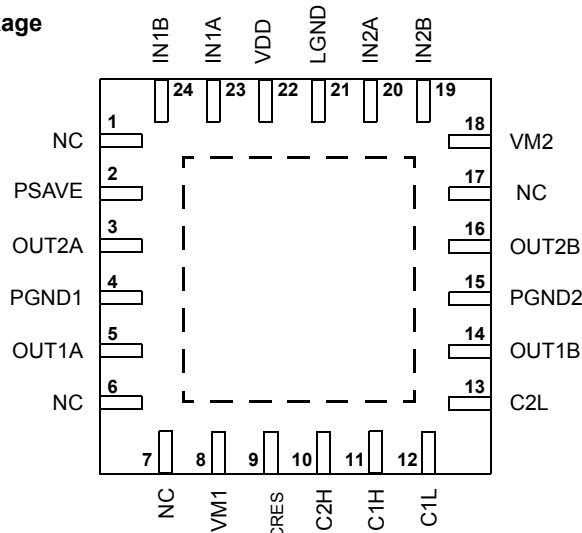


Figure 4. 17531A, 24-Terminal QFN Connections

Table 2. 17531A, 24-Terminal QFN Definitions

A functional description of each terminal can be found in the Functional Terminal Description section beginning on [page 10](#).

Terminal Number	Terminal Name	Formal Name	Definition
1, 6, 7, 17	NC	No Connect	This terminal is not used.
2	PSAVE	Power Save	Logic input controlling power save mode.
3	OUT2A	H-Bridge Output 2A	Output A of H-Bridge channel 2.
4	PGND1	Power Ground 1	High-current power ground 1.
5	OUT1A	H-Bridge Output 1A	Output A of H-Bridge channel 1.
8	VM1	Motor Drive Power Supply 1	Positive power source connection for H-Bridge 1 (Motor Drive Power Supply).
9	C <sub>RES</sub>	Predriver Power Supply	Internal triple charge pump output as pre-driver power supply.
10	C <sub>2H</sub>	Charge Pump 2H	Charge pump bucket capacitor 2 (positive pole).
11	C <sub>1H</sub>	Charge Pump 1H	Charge pump bucket capacitor 1 (positive pole).
12	C <sub>1L</sub>	Charge Pump 1L	Charge pump bucket capacitor 1 (negative pole).
13	C <sub>2L</sub>	Charge Pump 2L	Charge pump bucket capacitor 2 (negative pole).
14	OUT1B	H-Bridge Output 1B	Output B of H-Bridge channel 1.
15	PGND2	Power Ground 2	High-current power ground 2.
16	OUT2B	H-Bridge Output 2B	Output B of H-Bridge channel 2.
18	VM2	Motor Drive Power Supply 2	Positive power source connection for H-Bridge 2 (Motor Drive Power Supply).
19	IN2B	Logic Input Control 2B	Logic input control of OUT2B (refer to <a href="#">Table 6, Truth Table</a> , page 9).
20	IN2A	Logic Input Control 2A	Logic input control of OUT2A (refer to <a href="#">Table 6, Truth Table</a> , page 9).
21	LGND	Logic Ground	Low-current logic signal ground.
22	V <sub>DD</sub>	Logic Supply	Control circuit power supply terminal.
23	IN1A	Logic Input Control 1A	Logic input control of OUT1A (refer to <a href="#">Table 6, Truth Table</a> , page 9).
24	IN1B	Logic Input Control 1B	Logic input control of OUT1B (refer to <a href="#">Table 6, Truth Table</a> , page 9).

## MAXIMUM RATINGS

**Table 3. Maximum Ratings**

All voltages are with respect to ground unless otherwise noted. Exceeding these ratings may cause a malfunction or permanent damage to the device.

Ratings	Symbol	Value	Unit
Motor Supply Voltage	$V_M$	-0.5 to 11.0	V
Charge Pump Output Voltage	$V_{CRES}$	-0.5 to 14.0	V
Logic Supply Voltage	$V_{DD}$	-0.5 to 5.0	V
Signal Input Voltage	$V_{IN}$	-0.5 to $V_{DD}+0.5$	V
Driver Output Current			A
Continuous	$I_O$	0.7	
Peak <sup>(1)</sup>	$I_{OPK}$	1.4	
ESD Voltage			V
Human Body Model <sup>(2)</sup>	$V_{ESD1}$	±1200	
Machine Model <sup>(3)</sup>	$V_{ESD2}$	±150	
Operating Junction Temperature	$T_J$	-20 to 150	°C
Operating Ambient Temperature	$T_A$	-20 to 65	°C
Storage Temperature Range	$T_{STG}$	-65 to 150	°C
Thermal Resistance <sup>(4)</sup>	$R_{\theta JA}$	50	°C/W
Power Dissipation <sup>(5)</sup>	$P_D$		W
WMFP		1.0	
QFN		2.5	
Terminal Soldering Temperature <sup>(6)</sup>	$T_{SOLDER}$	260	°C

**Notes**

- $T_A = 25^\circ\text{C}$ . Pulse width = 10 ms at 200 ms intervals.
- ESD1 testing is performed in accordance with the Human Body Model ( $C_{ZAP} = 100 \text{ pF}$ ,  $R_{ZAP} = 1500 \Omega$ ).
- ESD2 testing is performed in accordance with the Machine Model ( $C_{ZAP} = 200 \text{ pF}$ ,  $R_{ZAP} = 0 \Omega$ ).
- For QFN only, mounted on 37 x 50 Cu area (1.6 mm FR-4 PCB).
- $T_A = 25^\circ\text{C}$ .
- Terminal soldering temperature limit is for 10 seconds maximum duration. Not designed for immersion soldering. Exceeding these limits may cause malfunction or permanent damage to the device.

## STATIC ELECTRICAL CHARACTERISTICS

**Table 4. Static Electrical Characteristics**

Characteristics noted under conditions  $T_A = 25^\circ\text{C}$ ,  $V_{DD} = 3.0\text{ V}$ ,  $V_M = 5.0\text{ V}$ ,  $\text{GND} = 0\text{ V}$  unless otherwise noted. Typical values noted reflect the approximate parameter means at  $T_A = 25^\circ\text{C}$  under nominal conditions unless otherwise noted.

Characteristic	Symbol	Min	Typ	Max	Unit
<b>POWER INPUT</b>					
Motor Supply Voltage (Using Internal Charge Pump) <sup>(7)</sup>	$V_{M-CP}$	2.0	5.0	8.6	V
Motor Supply Voltage ( $V_{CRES}$ Applied Externally) <sup>(8)</sup>	$V_{M-NCP}$	–	–	10	V
Gate Drive Voltage - Motor Supply Voltage ( $V_{CRES}$ Applied Externally) <sup>(9)</sup>	$V_{CRES-VM}$	5.0	6.0	–	V
Logic Supply Voltage	$V_{DD}$	2.7	3.0	3.6	V
Driver Quiescent Supply Current No Signal Input	$I_{QM}$	–	–	100	$\mu\text{A}$
Power Save Mode	$I_{QM-PSAVE}$	–	–	1.0	
Logic Quiescent Supply Current No Signal Input <sup>(10)</sup>	$I_{QVDD}$	–	–	1.0	mA
Power Save Mode	$I_{QVDD-PSAVE}$	–	–	1.0	
Operating Power Supply Current Logic Supply Current <sup>(11)</sup>	$I_{VDD}$	–	–	3.0	mA
Charge Pump Circuit Supply Current <sup>(12)</sup>	$I_{CRES}$	–	–	0.7	
Low $V_{DD}$ Detection Voltage <sup>(13)</sup>	$V_{DDET}$	1.0	1.6	2.5	V
Driver Output ON Resistance <sup>(14)</sup>	$R_{DS(ON)}$	–	0.8	1.2	Ohms
<b>GATE DRIVE</b>					
Gate Drive Voltage <sup>(12)</sup> No Current Load	$V_{CRES}$	12	13	13.5	V
Gate Drive Ability (Internally Supplied) $I_{CRES} = -1.0\text{ mA}$	$V_{CRESload}$	8.5	9.2	–	V
Recommended External Capacitance (C1L–C1H, C2L–C2H, $C_{RES-GND}$ )	$C_{CP}$	0.01	0.1	1.0	$\mu\text{F}$

**Notes**

7. Gate drive voltage  $V_{CRES}$  is applied from an external source.  $2 \times V_{DD} + V_M$  must be  $< V_{CRES\text{ max}}$  (13.5 V).
8. No internal charge pump used.  $V_{CRES}$  is applied from an external source.
9.  $R_{DS(ON)}$  is not guaranteed if  $V_{CRES} - V_M < 5.0\text{ V}$ . Also, function is not guaranteed if  $V_{CRES} - V_M < 3.0\text{ V}$ .
10.  $I_{QVDD}$  includes the current to pre-driver circuit.
11.  $I_{VDD}$  includes the current to predriver circuit at  $f_{IN} = 100\text{ kHz}$ .
12. At  $f_{IN} = 20\text{ kHz}$ .
13. Detection voltage is defined as when the output becomes high-impedance after  $V_{DD}$  drops below the detection threshold.  $V_{CRES}$  is applied from an external source.  $2 \times V_{DD} + V_M$  must be  $< V_{CRES\text{ max}}$  (13.5 V).
14.  $I_O = 0.7\text{ A}$  source + sink.

**Table 4. Static Electrical Characteristics (continued)**

Characteristics noted under conditions  $T_A = 25^\circ\text{C}$ ,  $V_{DD} = 3.0\text{ V}$ ,  $V_M = 5.0\text{ V}$ ,  $\text{GND} = 0\text{ V}$  unless otherwise noted. Typical values noted reflect the approximate parameter means at  $T_A = 25^\circ\text{C}$  under nominal conditions unless otherwise noted.

Characteristic	Symbol	Min	Typ	Max	Unit
CONTROL LOGIC					
Logic Input Voltage	$V_{IN}$	0	–	$V_{DD}$	V
Logic Inputs ( $2.7\text{ V} < V_{DD} < 3.3\text{ V}$ )					
High-Level Input Voltage	$V_{IH}$	$V_{DD} \times 0.7$	–	–	V
Low-Level Input Voltage	$V_{IL}$	–	–	$V_{DD} \times 0.3$	V
High-Level Input Current	$I_{IH}$	–	–	1.0	$\mu\text{A}$
Low-Level Input Current	$I_{IL}$	-1.0	–	–	$\mu\text{A}$
PSAVE Terminal Input Current Low	$I_{IL}\text{-PSAVE}$	–	50	100	$\mu\text{A}$

## DYNAMIC ELECTRICAL CHARACTERISTICS

**Table 5. Dynamic Electrical Characteristics**

Characteristics noted under conditions  $T_A = 25^\circ\text{C}$ ,  $V_{DD} = 3.0\text{ V}$ ,  $V_M = 5.0\text{ V}$ ,  $\text{GND} = 0\text{ V}$  unless otherwise noted. Typical values noted reflect the approximate parameter means at  $T_A = 25^\circ\text{C}$  under nominal conditions unless otherwise noted.

Characteristic	Symbol	Min	Typ	Max	Unit
<b>INPUT</b>					
Pulse Input Frequency	$f_{IN}$	–	–	200	kHz
Input Pulse Rise Time <sup>(15)</sup>	$t_R$	–	–	1.0 (16)	$\mu\text{s}$
Input Pulse Fall Time <sup>(17)</sup>	$t_F$	–	–	1.0 (16)	$\mu\text{s}$
<b>OUTPUT</b>					
Propagation Delay Time <sup>(18)</sup>					$\mu\text{s}$
Turn-ON Time	$t_{PLH}$	–	0.1	0.5	
Turn-OFF Time	$t_{PHL}$	–	0.1	0.5	
Charge Pump Wake-Up Time <sup>(19)</sup>	$t_{VGON}$	–	1.0	3.0	ms
Low-Voltage Detection Time	$t_{VDDDET}$	–	–	10	ms

**Notes**

15. Time is defined between 10% and 90%.
16. That is, the input waveform slope must be steeper than this.
17. Time is defined between 90% and 10%.
18. Output load is  $8.0\ \Omega$  DC.
19.  $C_{CP} = 0.1\ \mu\text{F}$ .



## TIMING DIAGRAMS

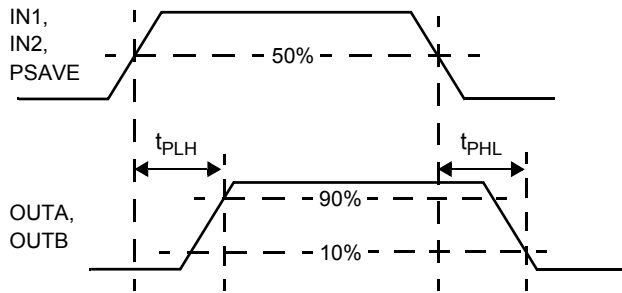
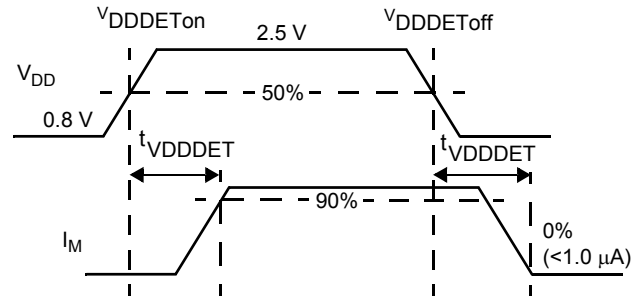
Figure 5.  $t_{PLH}$ ,  $t_{PHL}$ , and  $t_{PZH}$  Timing

Figure 6. Low-Voltage Detection Timing

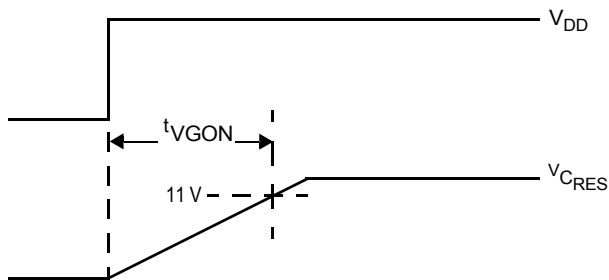


Figure 7. Charge Pump Timing

Table 6. Truth Table

INPUT			OUTPUT		Charge Pump and Low Voltage Detector
PSAVE	IN1A IN2A	IN1B IN2B	OUT1A OUT2A	OUT1B OUT2B	
L	L	L	L	L	RUN
L	H	L	H	L	RUN
L	L	H	L	H	RUN
L	H	H	Z	Z	RUN
H	X	X	Z	Z	STOP

H = High.

L = Low.

Z = High impedance.

X = Don't care.

PSAVE terminal is pulled up to  $V_{DD}$  with internal resistance.

## FUNCTIONAL DESCRIPTION

### INTRODUCTION

The 17531A is a monolithic dual H-Bridge ideal for portable electronic applications to control bipolar step motors and brush DC motors such as those found in camera lens assemblies, camera shutters, and optical disk drives. The device features an on-board charge pump, as well as built-in shoot-through current protection and undervoltage shutdown.

The 17531A has four operating modes: Forward, Reverse, Brake, and Tri-Stated (High Impedance). The MOSFETs comprising the output bridge have a total source + sink  $R_{DS(ON)} \leq 1.2 \Omega$ .

The 17531A can simultaneously drive two brush DC motors or one bipolar step motor. The drivers are designed to be PWM'ed at frequencies up to 200 kHz.

### FUNCTIONAL TERMINAL DESCRIPTION

#### LOGIC SUPPLY (VDD)

The  $V_{DD}$  terminal carries the logic supply voltage and current into the logic sections of the IC. VDD has an undervoltage threshold. If the supply voltage drops below the undervoltage threshold, the output power stage switches to a tri-state condition. When the supply voltage returns to a level that is above the threshold, the power stage automatically resumes normal operation according to the established condition of the input terminals.

#### LOGIC INPUT CONTROL (IN1A, IN1B, IN2A, AND IN2B)

These logic input terminals control each H-Bridge output. IN1A logic HIGH = OUT1A HIGH. However, if all inputs are taken HIGH, the outputs bridges are both tri-stated (refer to [Table 6, Truth Table](#), page 9).

#### POWER SAVE (PSAVE)

The PSAVE terminal is a HIGH = TRUE power save mode input. When PSAVE = HIGH, all H-Bridge outputs (OUT1A, OUT1B, OUT2A, and OUT2B) are tri-stated (High-Z), regardless of logic inputs (IN1A, IN1B, IN2A, and IN2B) states, and the internal charge pump and low voltage detection current are shut off to save power.

#### H-BRIDGE OUTPUT (OUT1A, OUT1B, OUT2A, AND OUT2B)

These terminals provide connection to the outputs of each of the internal H-Bridges (see [Figure 2, 17531A Simplified Internal Block Diagram](#), page 2).

#### MOTOR DRIVE POWER SUPPLY (VM1 AND VM2)

The VM terminals carry the main supply voltage and current into the power sections of the IC. This supply then becomes controlled and/or modulated by the IC as it delivers the power to the loads attached between the OUTput terminals. All VM terminals must be connected together on the printed circuit board.

#### CHARGE PUMP (C1L AND C1H, C2L AND C2H)

These two pairs of terminals, the C1L and C1H and the C2L and C2H, connect to the external bucket capacitors required by the internal charge pump. The typical value for the bucket capacitors is 0.1  $\mu\text{F}$ .

#### PREDRIVER POWER SUPPLY (CRES)

The CRES terminal is the output of the internal charge pump. Its output voltage is approximately three times of VDD voltage. The VCRES voltage is power supply for the internal predriver circuit of H-Bridges.

#### POWER GROUND (PGND)

Power ground terminals. They must be tied together on the PCB.

#### LOGIC GROUND (LGND)

Logic ground terminal.

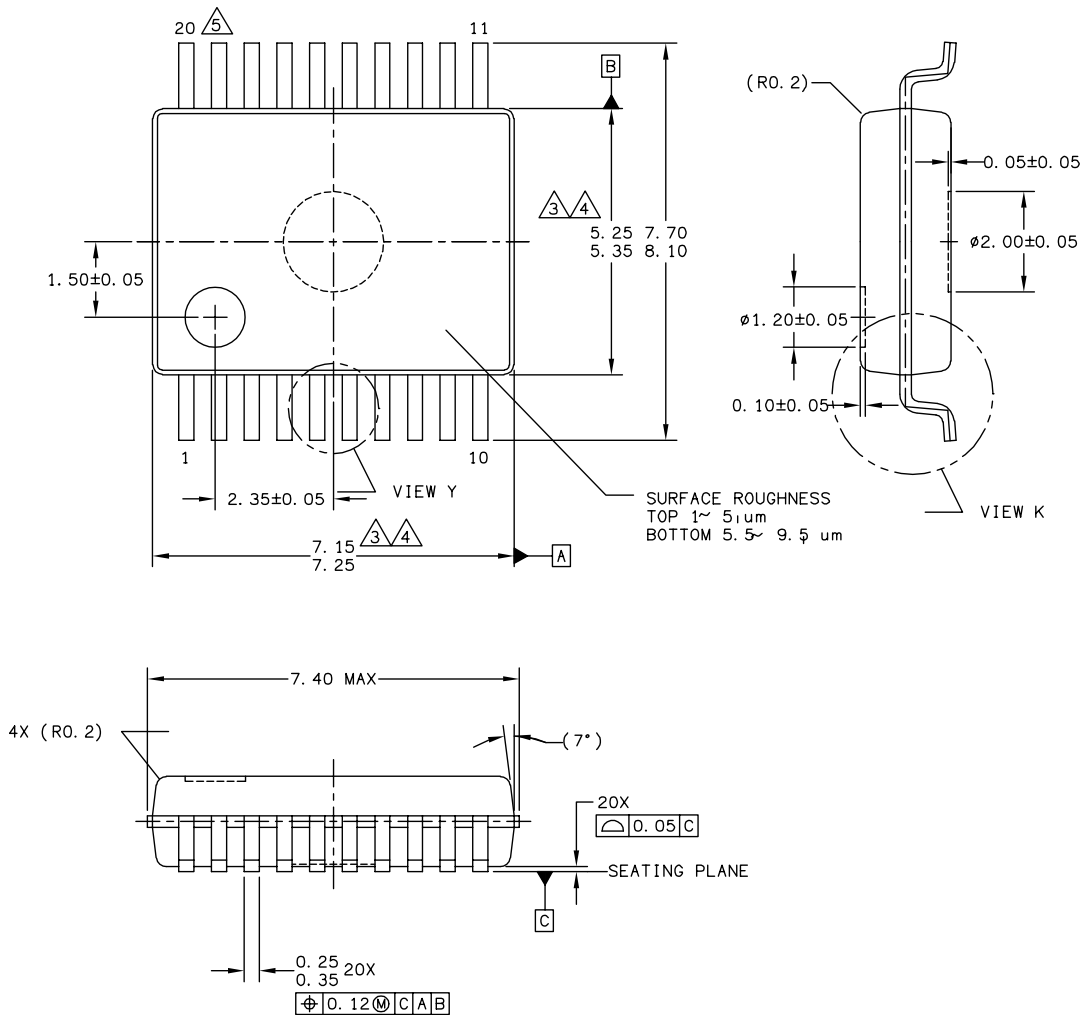


# PACKAGING

## PACKAGE DIMENSIONS

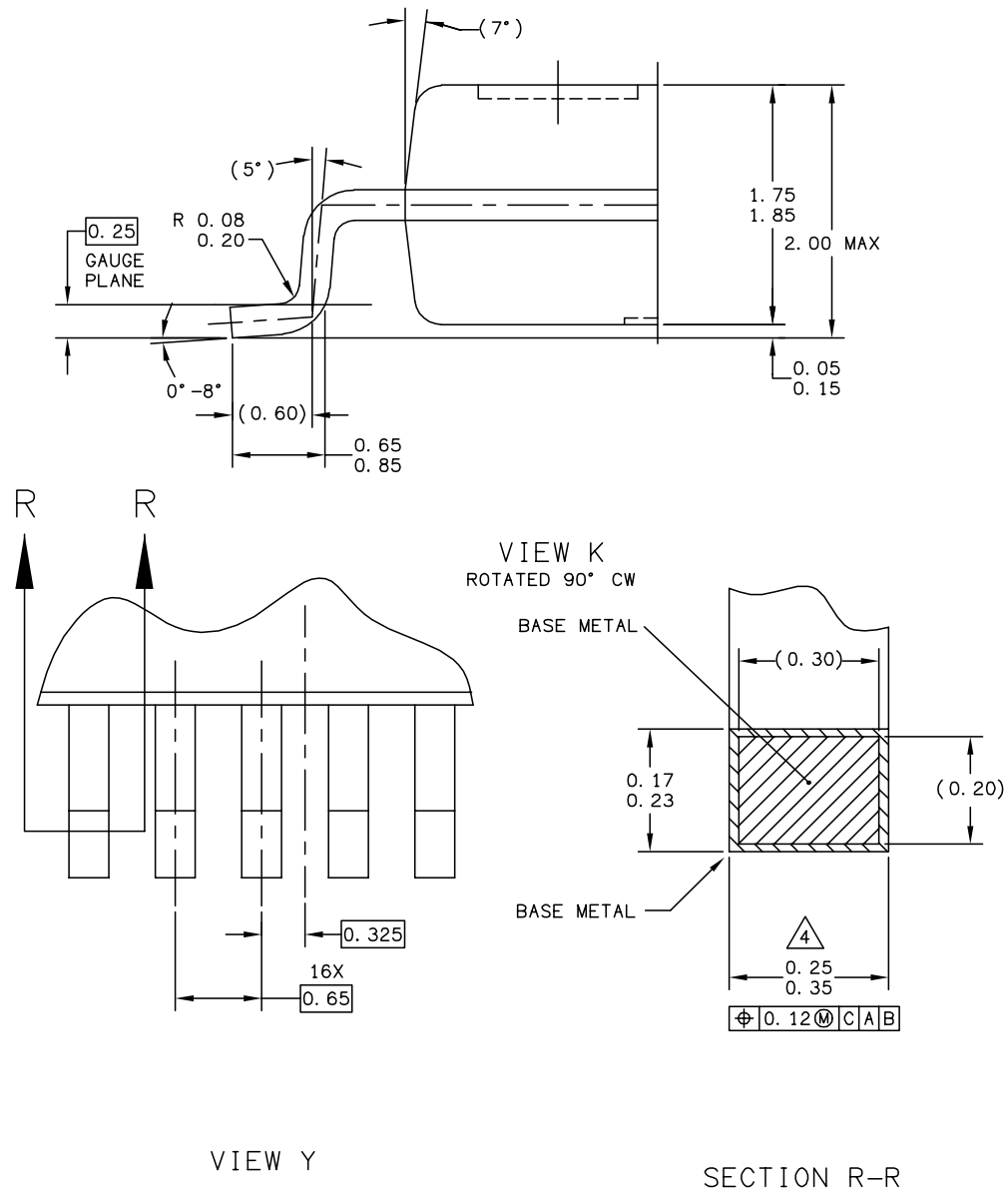
For the most current package revision, visit [www.freescale.com](http://www.freescale.com) and perform a keyword search using the “98A” drawing number listed below.

**EV (Pb-FREE) SUFFIX**  
20-LEAD VMFP  
PLASTIC PACKAGE  
98ASA10816D  
ISSUE A



© FREESCALE SEMICONDUCTOR, INC. ALL RIGHTS RESERVED.	<b>MECHANICAL OUTLINE</b>	PRINT VERSION NOT TO SCALE	
TITLE: EIAJ VMFP 20LD, 0.65 PITCH	DOCUMENT NO: 98ASA10616D	REV: A	
	CASE NUMBER: 1569-01	20 JUN 2005	
	STANDARD: NON-JEDEC		

**EV (Pb-FREE) SUFFIX**  
20-LEAD VMFP  
PLASTIC PACKAGE  
98ASA10816D  
ISSUE A



© FREESCALE SEMICONDUCTOR, INC. ALL RIGHTS RESERVED.	<b>MECHANICAL OUTLINE</b>	PRINT VERSION NOT TO SCALE	
TITLE: EIAJ VMFP 20LD, 0.65 PITCH	DOCUMENT NO: 98ASA10616D	REV: A	
	CASE NUMBER: 1569-01	20 JUN 2005	
	STANDARD: NON-JEDEC		

**EV (Pb-FREE) SUFFIX**  
20-LEAD VMFP  
PLASTIC PACKAGE  
98ASA10816D  
ISSUE A

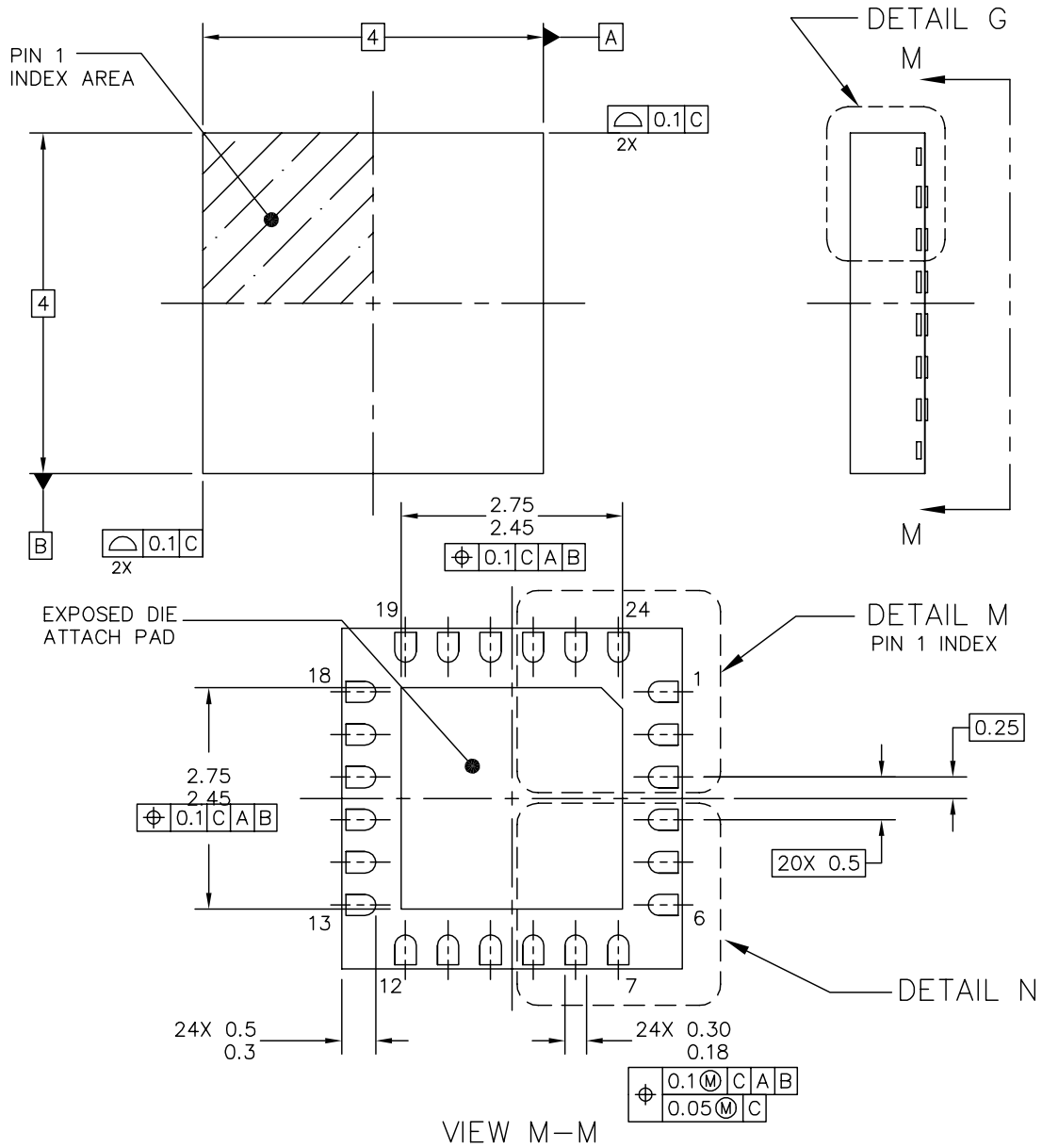
NOTES:

- 1 DIMENSIONING AND TOLERANCING PER ASME Y14.5M - 1994.
- 2 ALL DIMENSIONS ARE IN MILLIMETERS.
- 3 DIMENSIONS DO NOT INCLUDE MOLD FLASH, PROTRUSIONS OR GATE BURRS.  
MOLD FLASH, PROTRUSIONS OR GATE BURRS SHALL NOT EXCEED 0.10 ANY SIDE.  
DIMENSIONS DO NOT INCLUDE INTERLEAD FLASH OR PROTRUSION.  
INTERLEAD FLASH OR PROTRUSION SHALL NOT EXCEED 0.15 PER SIDE.
- 4 DIMENSIONS ARE DETERMINED AT THE OUTMOST EXTREMES OF THE PLASTIC BODY  
EXCLUSIVE OF MOLD FLASH, TIE BAR BURRS, GATE BURRS, AND INTERLEAD FLASH,  
BUT INCLUDING ANY MISMATCH BETWEEN THE TOP AND BOTTOM OF THE PLASTIC BODY.
- 5 TERMINAL NUMBER ARE SHOWN FOR REFERENCE ONLY.

© FREESCALE SEMICONDUCTOR, INC. ALL RIGHTS RESERVED.	<b>MECHANICAL OUTLINE</b>	PRINT VERSION NOT TO SCALE	
TITLE: EIAJ VMFP 20LD, 0.65 PITCH	DOCUMENT NO: 98ASA10616D	REV: A	
	CASE NUMBER: 1569-01	20 JUN 2005	
	STANDARD: NON-JEDEC		



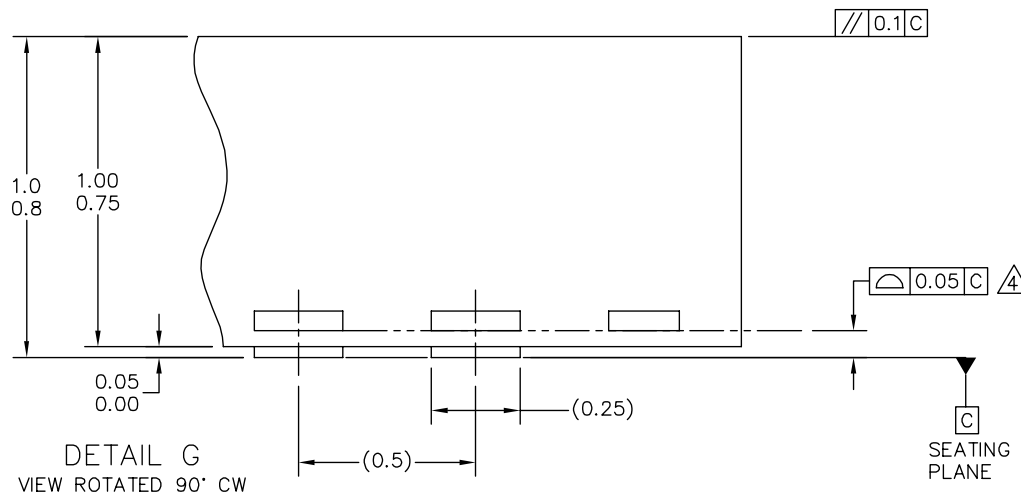
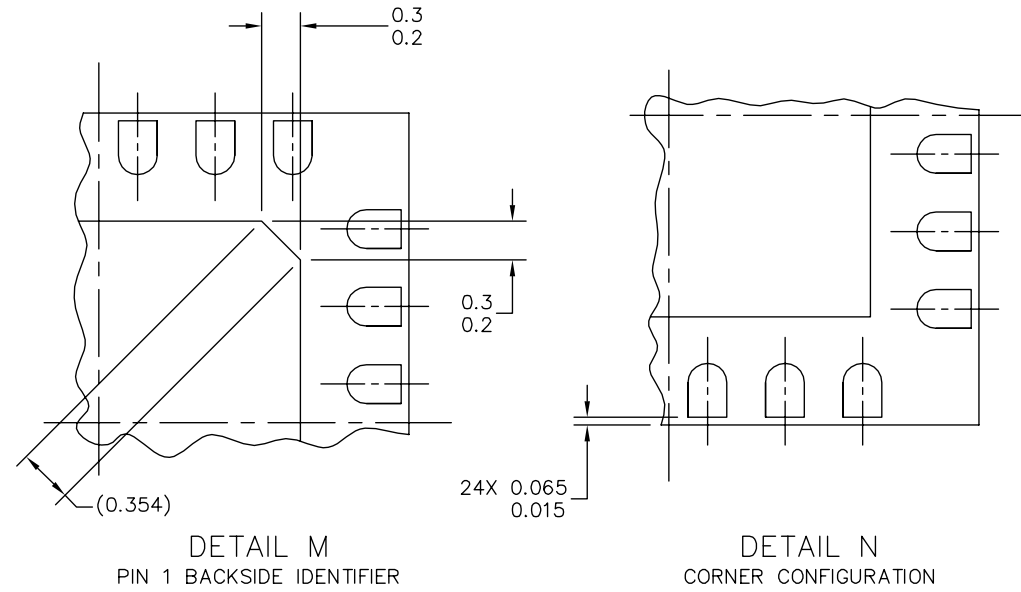
EP (Pb-FREE) SUFFIX  
24-LEAD QFN  
PLASTIC PACKAGE  
98ARL10577D  
ISSUE A



© FREESCALE SEMICONDUCTOR, INC. ALL RIGHTS RESERVED.	<b>MECHANICAL OUTLINE</b>	PRINT VERSION NOT TO SCALE
TITLE: THERMALLY ENHANCED QUAD FLAT NON-LEADED PACKAGE (QFN) 24 TERMINAL, 0.5 PITCH (4 X 4 X 1)	DOCUMENT NO: 98ARL10577D	REV: A
	CASE NUMBER: 1508-01	03 AUG 2005
	STANDARD: NON-JEDEC	




**EP (Pb-FREE) SUFFIX**  
24-LEAD QFN  
PLASTIC PACKAGE  
98ARL10577D  
ISSUE A



© FREESCALE SEMICONDUCTOR, INC. ALL RIGHTS RESERVED.	<b>MECHANICAL OUTLINE</b>	PRINT VERSION NOT TO SCALE	
TITLE: THERMALLY ENHANCED QUAD FLAT NON-LEADED PACKAGE (QFN) 24 TERMINAL, 0.5 PITCH (4 X 4 X 1)	DOCUMENT NO: 98ARL10577D	REV: A	
	CASE NUMBER: 1508-01	03 AUG 2005	
	STANDARD: NON-JEDEC		

**EP (Pb-FREE) SUFFIX**  
 24-LEAD QFN  
 PLASTIC PACKAGE  
 CASE 1508-01  
 ISSUE A

NOTES:

1. ALL DIMENSIONS ARE IN MILLIMETERS.
2. DIMENSIONING AND TOLERANCING PER ASME Y14.5M-1994.
3. THE COMPLETE JEDEC DESIGNATOR FOR THIS PACKAGE IS: HF-PQFP-N.
4.  COPLANARITY APPLIES TO LEADS AND DIE ATTACH PAD.

© FREESCALE SEMICONDUCTOR, INC. ALL RIGHTS RESERVED.	<b>MECHANICAL OUTLINE</b>	PRINT VERSION NOT TO SCALE	
TITLE: THERMALLY ENHANCED QUAD FLAT NON-LEADED PACKAGE (QFN) 24 TERMINAL, 0.5 PITCH (4 X 4 X 1)	DOCUMENT NO: 98ARL10577D	REV: A	
	CASE NUMBER: 1508-01	03 AUG 2005	
	STANDARD: NON-JEDEC		

**REVISION HISTORY**

REVISION	DATE	DESCRIPTION OF CHANGES
2.0	9/2005	<ul style="list-style-type: none"><li>• Implemented Revision History page</li><li>• Converted to Freescale format</li></ul>
3.0	2/2008	<ul style="list-style-type: none"><li>• Corrected Table 2, Pin Definitiuons on page 4.</li></ul>

## **How to Reach Us:**

### **Home Page:**

[www.freescale.com](http://www.freescale.com)

### **Web Support:**

<http://www.freescale.com/support>

### **USA/Europe or Locations Not Listed:**

Freescale Semiconductor, Inc.  
Technical Information Center, EL516  
2100 East Elliot Road  
Tempe, Arizona 85284  
+1-800-521-6274 or +1-480-768-2130  
[www.freescale.com/support](http://www.freescale.com/support)

### **Europe, Middle East, and Africa:**

Freescale Halbleiter Deutschland GmbH  
Technical Information Center  
Schatzbogen 7  
81829 Muenchen, Germany  
+44 1296 380 456 (English)  
+46 8 52200080 (English)  
+49 89 92103 559 (German)  
+33 1 69 35 48 48 (French)  
[www.freescale.com/support](http://www.freescale.com/support)

### **Japan:**

Freescale Semiconductor Japan Ltd.  
Headquarters  
ARCO Tower 15F  
1-8-1, Shimo-Meguro, Meguro-ku,  
Tokyo 153-0064  
Japan  
0120 191014 or +81 3 5437 9125  
[support.japan@freescale.com](mailto:support.japan@freescale.com)

### **Asia/Pacific:**

Freescale Semiconductor Hong Kong Ltd.  
Technical Information Center  
2 Dai King Street  
Tai Po Industrial Estate  
Tai Po, N.T., Hong Kong  
+800 2666 8080  
[support.asia@freescale.com](mailto:support.asia@freescale.com)

### **For Literature Requests Only:**

Freescale Semiconductor Literature Distribution Center  
P.O. Box 5405  
Denver, Colorado 80217  
1-800-441-2447 or 303-675-2140  
Fax: 303-675-2150  
[LDCForFreescaleSemiconductor@hibbertgroup.com](mailto:LDCForFreescaleSemiconductor@hibbertgroup.com)

RoHS-compliant and/or Pb-free versions of Freescale products have the functionality and electrical characteristics of their non-RoHS-compliant and/or non-Pb-free counterparts. For further information, see <http://www.freescale.com> or contact your Freescale sales representative.

For information on Freescale's Environmental Products program, go to <http://www.freescale.com/epp>.

Information in this document is provided solely to enable system and software implementers to use Freescale Semiconductor products. There are no express or implied copyright licenses granted hereunder to design or fabricate any integrated circuits or integrated circuits based on the information in this document.

Freescale Semiconductor reserves the right to make changes without further notice to any products herein. Freescale Semiconductor makes no warranty, representation or guarantee regarding the suitability of its products for any particular purpose, nor does Freescale Semiconductor assume any liability arising out of the application or use of any product or circuit, and specifically disclaims any and all liability, including without limitation consequential or incidental damages. "Typical" parameters that may be provided in Freescale Semiconductor data sheets and/or specifications can and do vary in different applications and actual performance may vary over time. All operating parameters, including "Typicals", must be validated for each customer application by customer's technical experts. Freescale Semiconductor does not convey any license under its patent rights nor the rights of others. Freescale Semiconductor products are not designed, intended, or authorized for use as components in systems intended for surgical implant into the body, or other applications intended to support or sustain life, or for any other application in which the failure of the Freescale Semiconductor product could create a situation where personal injury or death may occur. Should Buyer purchase or use Freescale Semiconductor products for any such unintended or unauthorized application, Buyer shall indemnify and hold Freescale Semiconductor and its officers, employees, subsidiaries, affiliates, and distributors harmless against all claims, costs, damages, and expenses, and reasonable attorney fees arising out of, directly or indirectly, any claim of personal injury or death associated with such unintended or unauthorized use, even if such claim alleges that Freescale Semiconductor was negligent regarding the design or manufacture of the part.

Freescale™ and the Freescale logo are trademarks of Freescale Semiconductor, Inc. All other product or service names are the property of their respective owners.

© Freescale Semiconductor, Inc., 2005. All rights reserved.